

POINT : Car Window Shade 、 Printer 、 Pump 、 Drill & Screwdriver

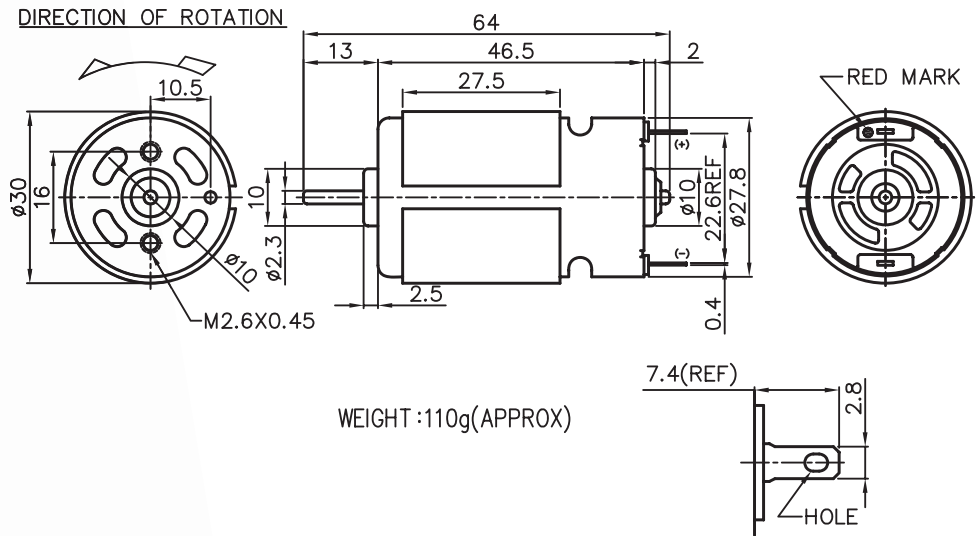

MODEL	VOLTAGE		NO LOAD		AT MAXIMUM EFFICIENCY					STALL			
	OPERATING RANGE	NOMNAL	SPEED	CURRENT	SPEED	CURRENT	TORQUE	OUTPUT	EFF	CURRENT	TORQUE		
			rpm	A	rpm	A	g-cm	mN-m	W	%	A	g-cm	mN-m
JD5FN-2466	12.0 - 36.0	30.0V CONSTANT	15700	0.18	13900	1.12	173	16.96	24.89	77	9.07	1655	162.25
JC5FN-2655	12.0 - 24.0	12.0V CONSTANT	6700	0.16	5700	1.04	151	14.80	8.92	71	6.30	1084	106.27
JD5FN-3230	6.0 - 12.0	6.0V CONSTANT	6400	0.25	5600	1.46	105	10.29	6.08	70	8.35	700	68.63
JD5FN-14180	12.0 - 24.0	24.0V CONSTANT	4200	0.06	3900	0.14	63	6.18	2.57	77	1.18	618	60.59

